

#5 Turnout LH (full size)

In Steve Monson's article on building switches in the June 2009 issue, there was an error on page 47. In the table called "Rail lengths (inches)," the entry for #5 closure/point rails should read "16 3/4."

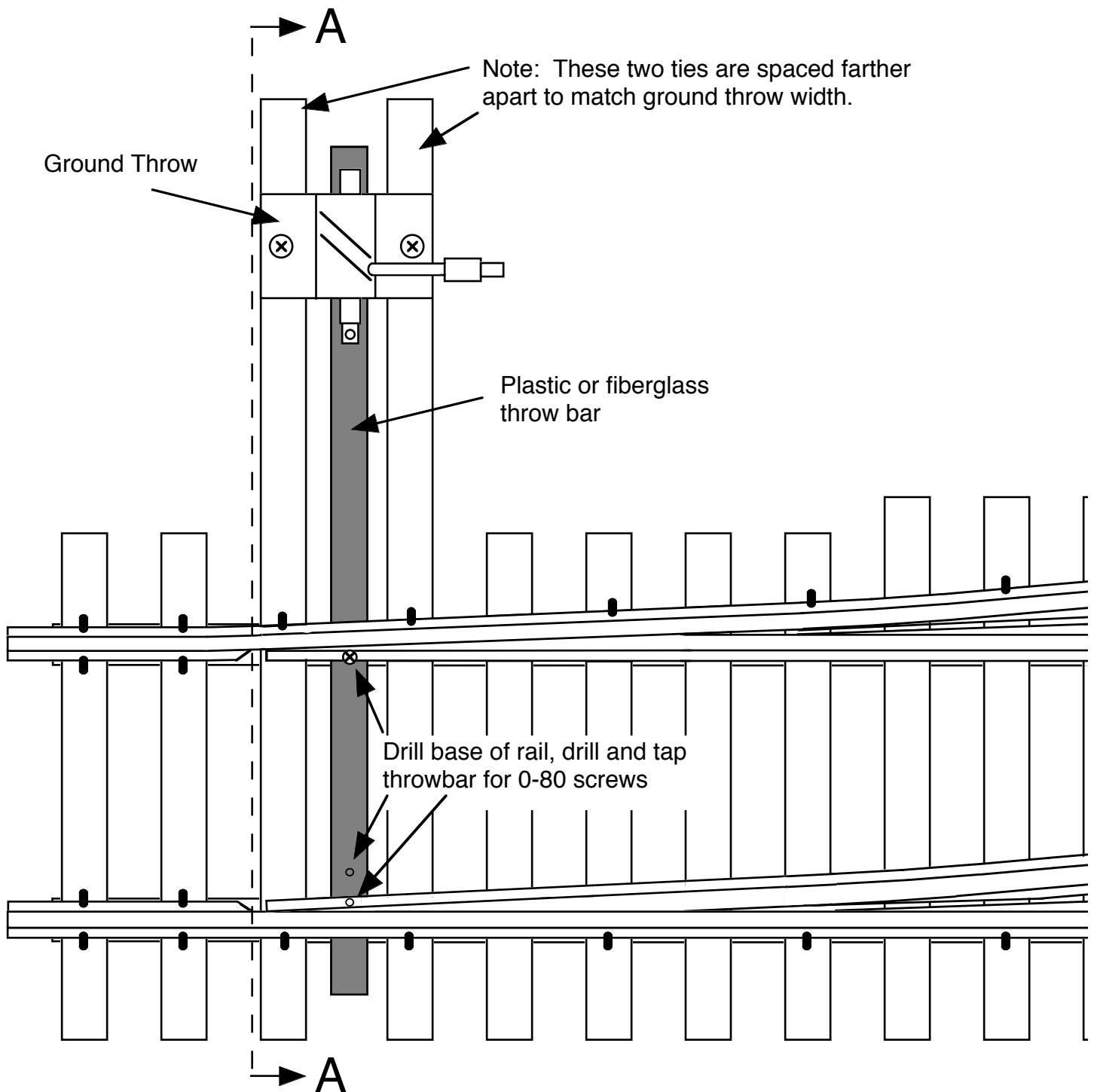

A - A

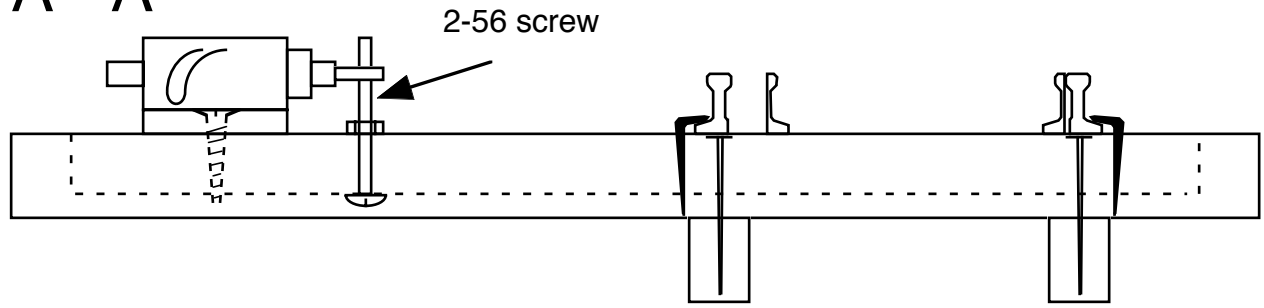

B - B

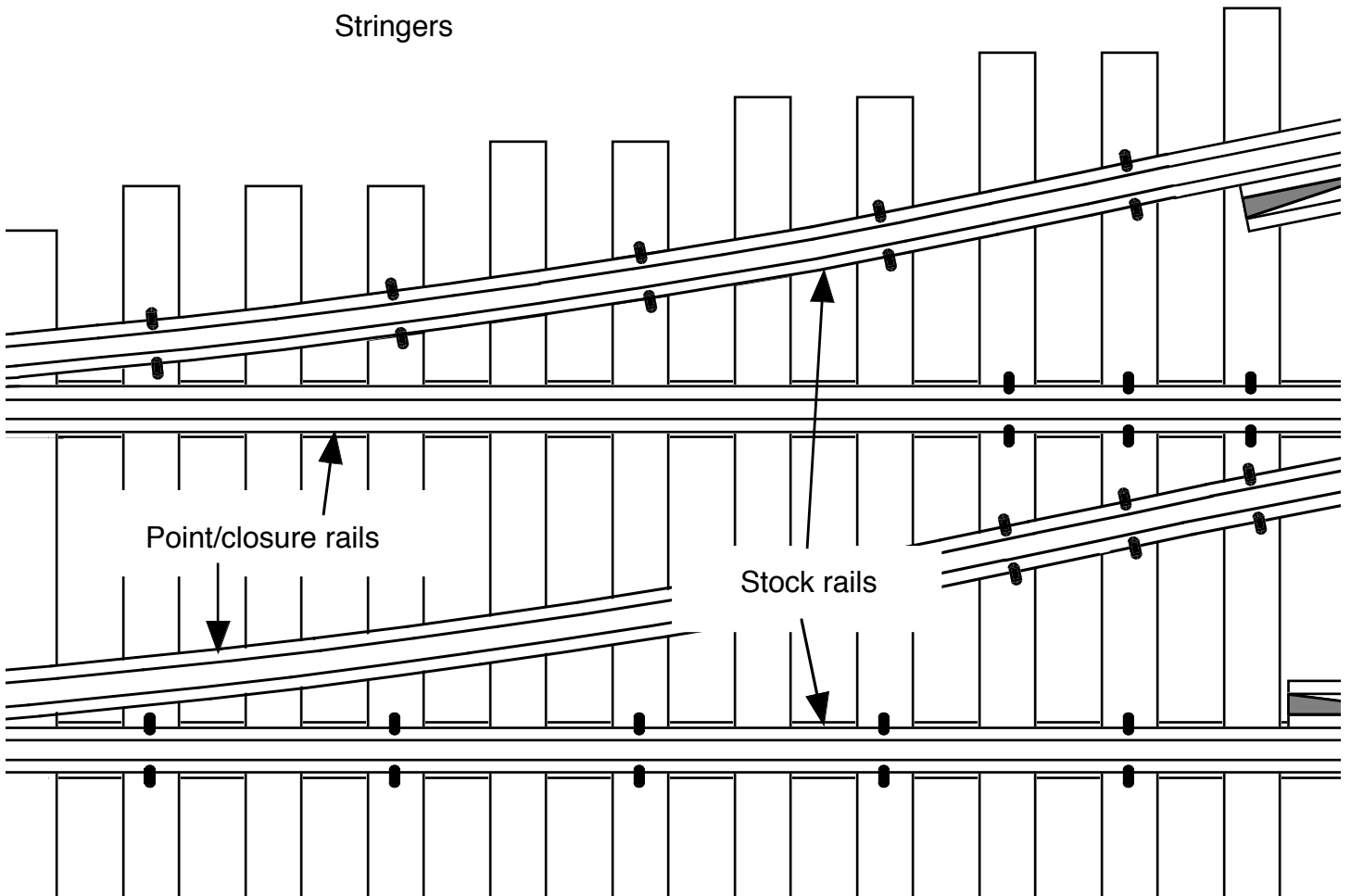
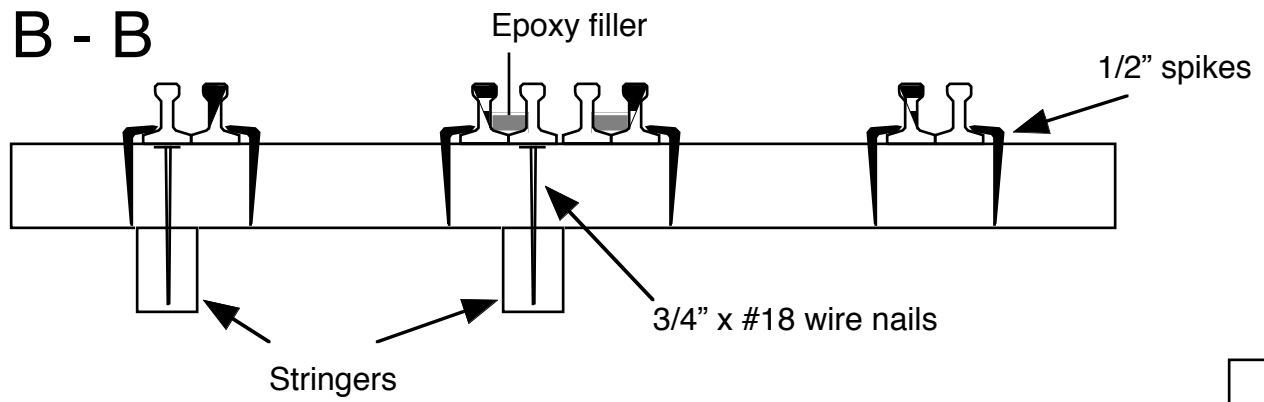

The length of the straight stock rail on each page is 7.5 inches (190.5mm)

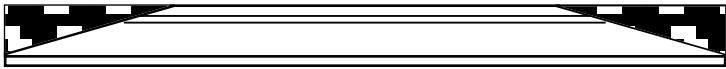

Guard rail with beveled ends

